



Universal TS Series

ROTARY POSITIVE DISPLACEMENT TWIN SCREW PUMPS



Users of Waukesha Cherry-Burrell brand pumps benefit from decades of continuing product improvement. Steady advances in design, metallurgy and fabrication techniques have yielded progressively higher levels of performance and service life.

The new Universal Twin Screw (TS) Series pump from SPX FLOW runs with the same reliability you've come to expect from SPX FLOW. Its versatile design improves processing time and maximizes productivity.

SPX FLOW, Inc. (NYSE:FLOW) is a leading manufacturer of innovative flow technologies, many of which help define the industry standard in the market segments they serve. It operates a sales and support network, centers of manufacturing excellence, and advanced engineering facilities throughout the world. Its cutting-edge flow components and process equipment portfolio includes a wide range of pumps, valves, heat exchangers, mixers, homogenizers, separators, filters, UHT, and drying technology that meet many application needs. Expert engineering capabilities also makes it a premium supplier of customized solutions and complete, turn-key packages to meet the most exacting of installation demands.

Incorporating many leading brands, SPX FLOW has a long history of serving the food and beverage, power and energy, and industrial market sectors. Its designs and engineered solutions help customers drive efficiency and productivity, increase quality and reliability, and meet the latest regulatory demands. In-depth understanding of applications and processes, state-of-the-art Innovation Centers, and advanced pilot/testing technology further assist in optimizing processes and reducing time lines to reliably meet production targets.

To learn more about SPX FLOW capabilities, its latest technology innovations and complete service offerings, please visit www.spxflow.com.

You can count on Universal TS Series pumps for:

RELIABLE PERFORMANCE -

Screws made from Waukesha Alloy 88 non-galling material allow the pump to run through incidental contact and reduce risk of pump damage if screws make contact

GENTLE PRODUCT HANDLING -

Pumps large particulates without degradation

RESPONSIVE SERVICE -

Extensive global distribution network with certified repair centers provide quick response times for parts and service

EASY MAINTENANCE -

Front loaded access to product side seals

PROCESS FLEXIBILITY -

Low inlet pressure requirement and a wide range of operating speeds allow for multiple duties including process and CIP supply. Bi-directional flow capability without making modifications to the pump.

SMOOTH OPERATION -

Reduces slip pulse in low inlet pressure, low viscosity, and high pressure conditions

REDUCED NOISE LEVELS -

Operating principle virtually eliminates pressure fluctuations



Minimize extra pumps, valves, and controls from your process

TYPICAL CONFIGURATION FOR PRODUCT AND CIP

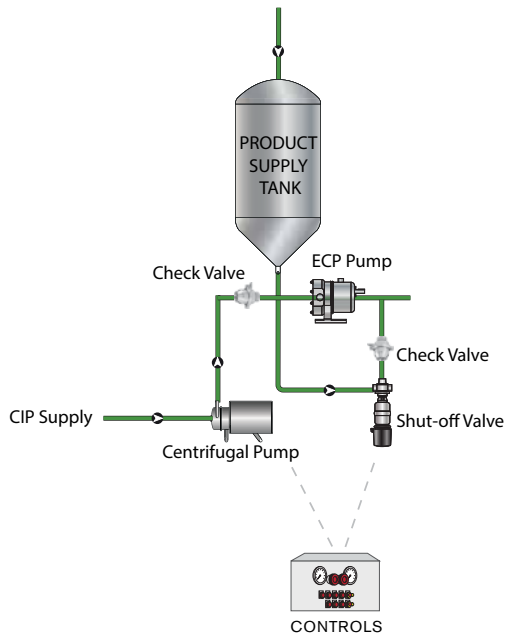

UNIVERSAL TS PUMP FOR BOTH PRODUCT AND CIP

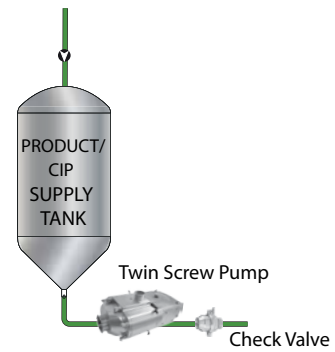

With its high suction capability, the Universal TS Series pump is both process and CIP capable, allowing you to reduce the number of pumps, valves, and control systems in your process and save capital equipment costs.

Choose the right screw pitch for your process

Three screw pitch options for all models offer a wide selection of capacities, pressures, flow rate profiles, and particle sizes. SPX FLOW pump specialists can advise you on the optimal pitch for your application.



Option 1: Wide pitch for applications requiring lower pressures with higher flow rates or a need to accommodate larger particulates



Option 2: Midrange pitch - offers a balance in pressure and flow velocities between the larger and smaller screw profiles



Option 3: Narrow pitch applications requiring higher pressures with lower flow rates

Typical product applications



Food and Beverage

Soups, Stews, Tomato Paste
Vegetables, Dressings
Chocolate, Fats & Oils
Batters, Cream Fillings
Brewery, Wort
Soft/Fruit Drinks
Meat Processing



Dairy

Cream, Milk
Cheese Curd & Whey
Cottage Cheese
Yogurt



Pharmaceutical/Cosmetics

Pill Pastes
Syrups, Extracts, Slurries
Face Creams & Lotions
Hair Styling Gels & Liquids
Dyes & Alcohols
Soaps
Cosmetics



Chemical/Industrial

Solvents, Paints
Fuels
Resins, Polymers & Sludges
Oil & Lubricants

New levels of sanitary performance. Long-life features.

PRODUCT FEATURES AND BENEFITS

Sanitary Features

- CIP capability standard. Pump body and cover are free draining
- Screw/shaft connection sealed from product zone
- Single and Double mechanical seal options
- All models include seal flush ports for optional double seal
- Steam-In-Place capable
- Stainless steel gear case standard

Installation Features

- Indexed splined shafts and screws provide positive engagement and ease installation of the screws
- Capable of bi-directional flow without having to change bearings or body orientation
- Non-galling Waukesha “88” alloy screws standard; permits running at tighter clearances and pumping a wide range of viscosities
- 316L stainless steel pump body and cover
- Product seal and barrier seal parts are identical; simplify assembly, reduce number of unique components
- All pumps are performance tested prior to shipment

Features

- Up to 375 psi (25.5 bar) pressure capability
- Special rotor nut designed for extended service
- No bearings in the product zone
- Large diameter 17-4 PH shafts for greater strength and stiffness. Helps reduce vibration and extends seal life
- Standard heavy duty stainless steel bearing frame
- Built with high precision needle roller element bearings
- Oil-lubricated bearings for positive lubrication over entire speed, temperature and pressure range
- Body retaining screws for maintaining mechanical seal contact during inspection
- Unique mechanical seal design utilizes common parts for inner and outer seal seats and rotary seals in a compact design

PRODUCT DIMENSIONS

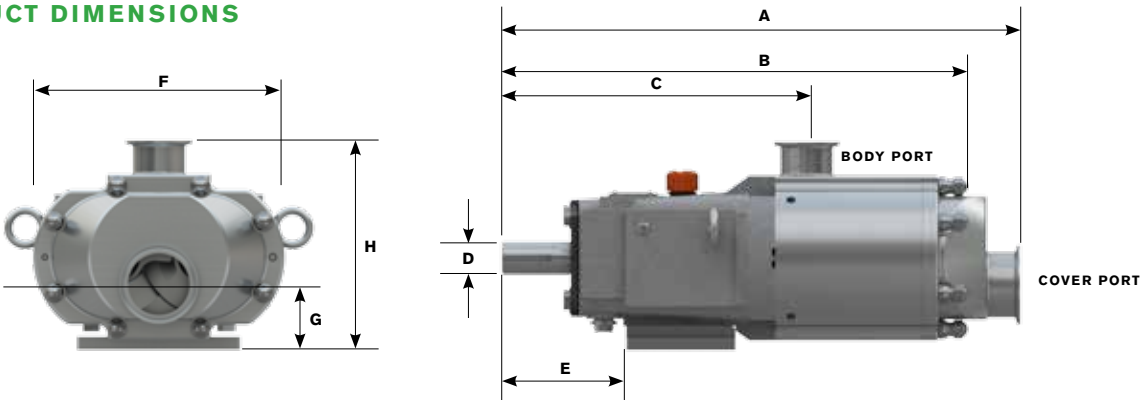

MODEL		A	B	C	D +.000 -.001	E	F	G	H	COVER PORT	BODY PORT	WEIGHT
015-UTS	in	16.40	15.32	10.27	0.875	4.07	7.68	2.20	6.76	1.50, 2.00	1.50, 2.00	87 lbs
	mm	417	389	261	22.23	103	195	56	172	38, 51	38, 51	39 kg
030-UTS	in	20.11	18.07	11.83	1.25	4.83	9.65	2.52	8.05	2.00, 3.00	2.00, 2.50	160 lbs
	mm	511	459	300	31.75	123	245	64	204	51, 76	51, 64	73 kg
130-UTS	in	25.81	23.37	15.29	1.625	5.25	13.12	3.98	10.68	3.00, 4.00	2.50, 3.00	385 lbs
	mm	656	594	388	41.28	133	332	101	271	76, 102	64, 76	175 kg
220-UTS	in	33.79	23.03	18.18	2.00	5.80	16.90	4.04	15.65	4.00, 6.00	4.00, 6.00	750 lbs
	mm	858	585	462	50.8	147	428	103	398	102, 152	102, 152	340 kg

NOTE: Dimensions are for guidance purposes only. Contact your SPX FLOW Representative for more detailed measurements.

PRODUCT SPECIFICATIONS
UNIVERSAL TS MODELS

MODEL	SCREW PITCH	DISPLACEMENT PER REVOLUTION		NOMINAL CAPACITY (MAX)		COVER PORT		BODY PORT		MAXIMUM PARTICULATE		PRESSURE RANGE (MAX)		MAXIMUM RPM	TEMP RANGE
		GAL	LITER	GPM	LPM	IN	MM	IN	MM	IN	MM	PSI	BAR		
015-UTS	16.5	0.02	0.08	70	265	2	51	1.5	38	0.33	8	375	25.5	3500	-40°F (-40°C) to 300°F (149°C)
	33	0.03	0.11	105	398					0.65	17				
	44	0.04	0.15	140	530					0.44*	11				
030-UTS	16.8	0.03	0.11	93	352	2.5	64	2	51	0.33	8	375	25.5	3100	
	28	0.05	0.19	155	587					0.55	14				
	42	0.08	0.30	248	939					0.83	21				
130-UTS	36.7	0.12	0.45	300	1136	4	102	2.5	64	0.72	18	375	25.5	2500	
	55	0.18	0.68	450	1703					1.09	28				
	73.4	0.24	0.91	600	2271					0.72*	18				
220-UTS	45	0.30	1.14	600	2271	4 or 6	102 or 152	4 or 6	102 or 152	0.89	22	375	25.5	2000	
	60	0.40	1.51	800	3028					1.18	30				
	90	0.61	2.31	1220	4618					1.77	45				

* Double start screws limit particulate size.

NOTE: Running for extended periods of time at high RPMs may require external gear box cooling equipment. If operation is required near the maximum allowable RPM, please contact SPX FLOW application engineering for confirmation of the correct pump configuration.

OPTIONS AND ACCESSORIES

Ports

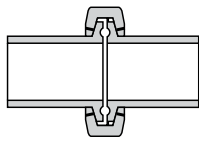

Sanitary Clamp
(S-Line*, I-Line and Q-Line)

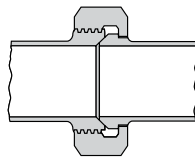

Bevel Seat

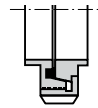

Optional European Types;
DIN, SMS, RJT

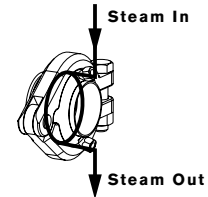

Optional Aseptic Ports

* S-Line standard

Contact factory for available rectangular flange inlets.

Screw Pitches



Narrow



Medium



Wide

O-Rings

FKM Standard

Fluoroelastomer (FKM), EPDM, Fluoroelastomer (FFKM)

Engineered for Performance and Long Life.

Waukesha Cherry-Burrell Universal TS Series provides:

High pressure capability - up to 375 psi/25.5 bar

Optimal seals - for most applications, plus interchangeability when needed

Compliant design - 3-A, USDA, ISO 9001:2008

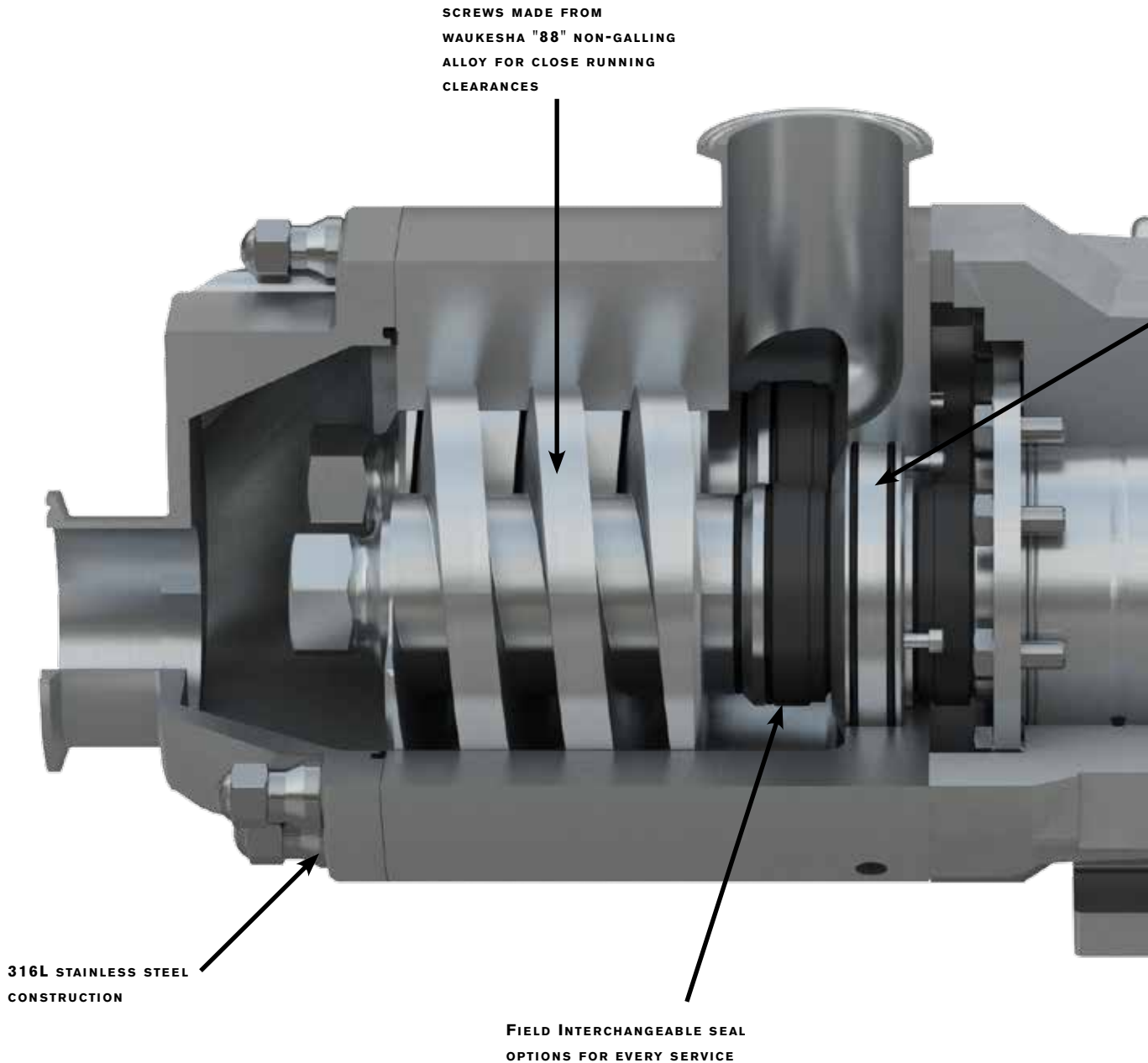

Seal Options

Single or Double Mechanical Seal*

Used with flushing fluid to cool, lubricate, and flush away residue. Ideal arrangement for severe service applications.

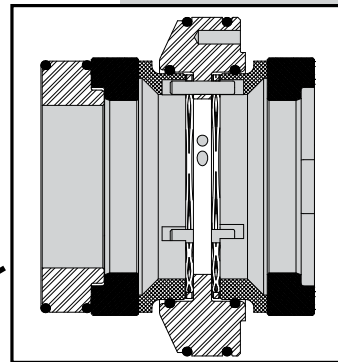

Double mechanical seal shown

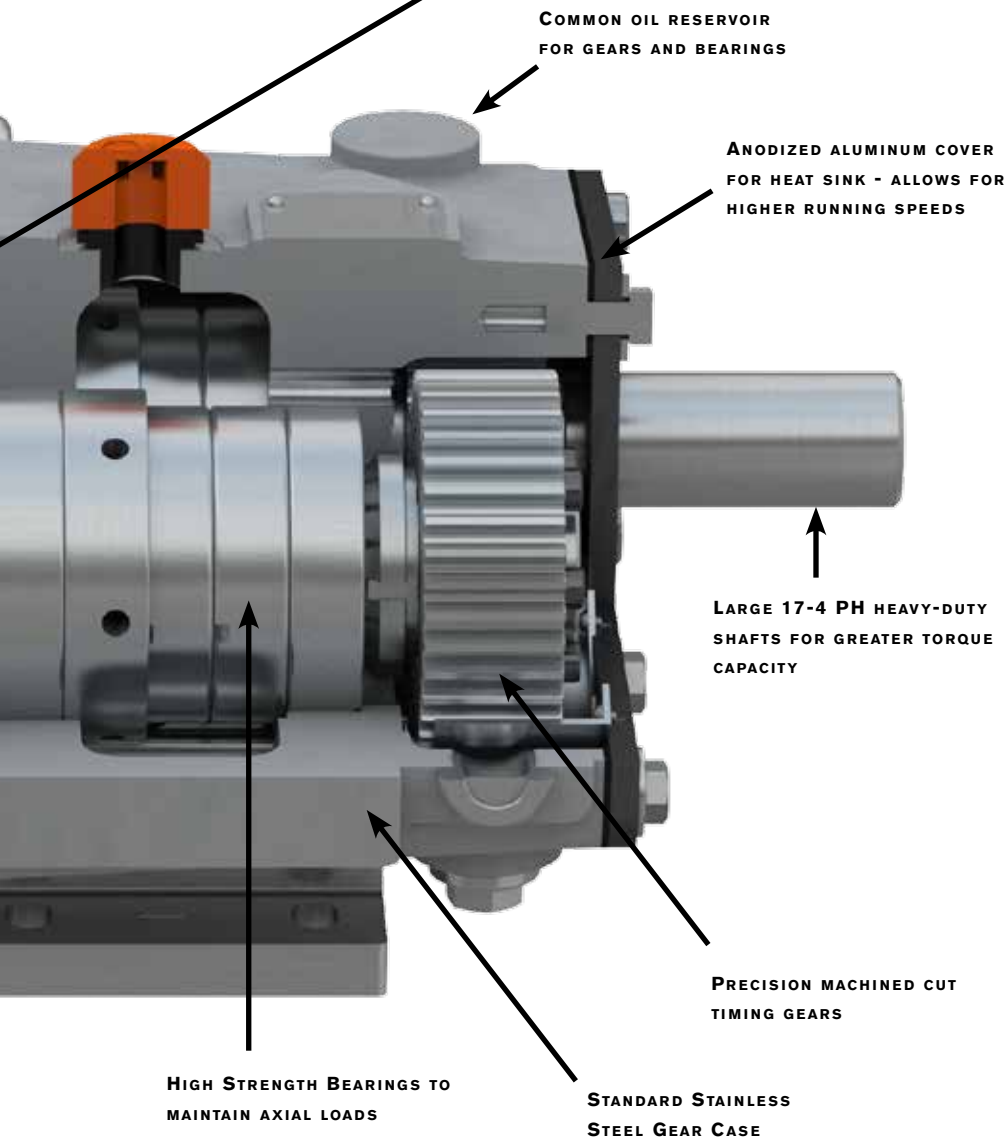

Elastomer choices for "O" rings:

- Fluoroelastomer (FKM)
- EPDM
- FFKM

*Mechanical seal material options:

- Carbon
- Silicon Carbide
- Tungsten Carbide

Rotary Positive Displacement Twin Screw Pumps

UNIVERSAL TS SERIES

SPXFLOW

For pump repair, choose the SPX FLOW maintenance program to meet your needs.

SPX FLOW Certified Pump Repair Centers

- Local distributors with factory trained service technicians
- Quick local response
- Genuine WCB parts
- Flexible repair programs to meet your needs
- Product warranty



Assembled and tested in Delavan, WI

CONTACT A SPX FLOW PUMP EXPERT TODAY AND FIND THE RIGHT PUMP FOR YOUR PROCESS

SPX FLOW

611 Sugar Creek Road

Delavan, WI 53115

P: (262) 728-1900 or (800) 252-5200

E: wcb@spxflow.com

Based in Charlotte, North Carolina, SPX FLOW, Inc. (NYSE: FLOW) is a multi-industry manufacturing leader. For more information, please visit www.spxflow.com

SPX FLOW, Inc. reserves the right to incorporate our latest design and material changes without notice or obligation.

Design features, materials of construction and dimensional data, as described in this bulletin, are provided for your information only and should not be relied upon unless confirmed in writing. Please contact your local sales representative for product availability in your region. For more information visit www.spxflow.com.

The green "S" and "X" are trademarks of SPX FLOW, Inc.

ISSUED 05/2017 FH-1801

COPYRIGHT © 2017 SPX FLOW, Inc.