



## LINCOLN SUPPLIERS INC.

1225 12<sup>th</sup> Avenue NW Owatonna, MN 55060

Phone 800-622-8425 Fax 507-451-2968

Visit our website [www.lincolnsuppliers.com](http://www.lincolnsuppliers.com)



### Waukesha Positive Displacement Pump Repair Program

#### Remanufacturing, Reconditioning and Repair

Streamline your repair process:

Lincoln is a SPX Certified Pump Repair Center

**Free inbound freight to Lincoln for evaluation/repair.**

- Authorized distributor with factory trained and certified service technicians.
- Quick local response.
- Genuine SPX parts.
- Flexible repair programs to meet your needs.
- Local warranty.



**\*Contact Lincoln for additional information on the WCB take 5 program for trade in discounts on new and remanufactured positive displacement pumps today\***

Waukesha  
Cherry-Burrell®

take

5

WCB is dedicated to increasing productivity, product quality and profitability for our customers. Take advantage of these **MONEY \$AVING** opportunities.

1

### NEW PUMP PURCHASE

**NEW WCB PD Pumps -  
Manufactured and Engineered to Meet  
Your Most Demanding Applications**

#### Universal I Pump Series

- Easy disassembly for clean-out-of-place (COP).
- The recognized industry standard for over 65 years.

#### Universal II Pump Series

- Clean-in-place (CIP) capabilities.
- Pressures up to 500 psi.

2

### UNIVERSAL "E" PROGRAM

WCB has bundled the most commonly specified features available on the Universal I, models 6 through 220.

Ask your local distributor or call 1-800-252-5200 for further details on any of the above programs.

With money saving options like these why would you look anywhere else?

3

### TRADE-UP

Now is the time to "Trade-Up" to the industry champion WCB Universal pump. We accept "Trade-Ins" of working competitor's positive displacement pumps. Why keep an obsolete or troublesome pump in your facility when you can have a Waukesha Universal Pump? Receiving the new pump before removing the older pump from your plant translating to **NO DOWNTIME** for you! Isn't it time you traded up to a WCB Universal Pump?

4

### TRADE-IN

Have a WCB pump you are no longer using? Need a larger or smaller pump for a new application? Time to change to the clean-in-place Universal II design? Take advantage of our exclusive "Trade-In" Program, by sending us your old Waukesha Universal Pump when you purchase a new pump. Best of all there is **NO DOWNTIME!**

5

### REMANUFACTURING

When your pump can no longer be repaired, who better to trust for the reconditioning of your pump than the company who originally manufactured it? Plus all remanufactured pumps carry a full factory warranty. This program includes our special "NO DOWNTIME" feature, supplying you with a replacement pump before returning your old pump.

(All savings based upon market price of new pump.)

SPX®

611 Sugar Creek Road • Delavan, WI 53115 USA  
Phone (800) 252-5200 or (262) 728-1900 Fax (800) 252-5012 or (262) 728-4904  
E-Mail [wcb@spx.com](mailto:wcb@spx.com) Website: [www.gowcb.com](http://www.gowcb.com)

Waukesha  
Cherry-Burrell®

take

5



If a new pump purchase is not  
in your budget...

★ **Pump Remanufacture Program** - The Remanufacture Program will restore your Universal series pumps\* to new pump status as many times as possible. Regardless of condition, pumps will be remanufactured **TWICE GUARANTEED**.

★ **Factory Warranty** - You get a **NEW Full-Year Warranty** along with the same quality, performance-tested, rugged reliability you've come to expect from Waukesha Cherry-Burrell.

★ **Pump Exchange** - Our convenient Pump Exchange Policy allows you to receive your newly remanufactured pump prior to returning your worn unit resulting in **NO DOWNTIME**.

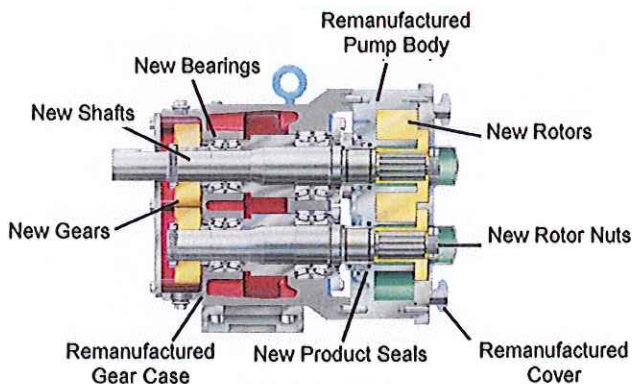

\*Excluded are Ductile Iron Pumps, Universal Lobe Pumps and pumps that have been modified by unauthorized repair or reconditioning facilities.

5

## REMANUFACTURING

When your pump can no longer be repaired, who better to trust for the reconditioning of your pump than the company who originally manufactured it? Plus all remanufactured pumps carry a full factory warranty. This program includes our special "NO DOWNTIME" feature, supplying you with a replacement pump before returning your old pump.

★ **Standard Remanufacturing** - The program provides remanufacturing to standard oversized tolerances. This option allows interchangeability of parts.

- ★ The remanufacture process includes:
- Precision machining of body and cover to standard oversize dimensions.
  - New oversized rotors installed to restore original performance.
  - New shafts, bearings, seals and rotor nuts.
  - Remanufactured body, cover and gear case.
  - Assembly of pump by factory trained technicians using ISO 9001 procedures.
  - All pumps are tested to validate performance.

SPX

611 Sugar Creek Road • Delavan, WI 53115 USA  
Phone (800) 252-5200 or (262) 728-1900 Fax (800) 252-5012 or (262) 728-4904  
E-Mail [wcb@spx.com](mailto:wcb@spx.com) Website: [www.gowcb.com](http://www.gowcb.com)